



FULL SIZE CONVECTION OVENS

FULL SIZE CONVECTION OVENS



JCO-40B

MODEL NO.	DESCRIPTION
<input type="checkbox"/> JCO-40B	SINGLE FULL-SIZE GAS CONVECTION OVEN
<input type="checkbox"/> JCO-240B	DOUBLE FULL-SIZE GAS CONVECTION OVEN

STANDARD FEATURES

- Full angle-iron frame
- Stainless steel front, top, and sides
- One dual pane thermal glass window encased in stainless steel door frame
- Porcelain door handle with simultaneous door operation
- Triple-mounted pressure lock door design with turnbuckle assembly
- Modular slide out front control panel for easy cleaning
- Solid mineral fiber insulation at top, back, sides and bottom
- Stainless steel baking compartment liner
- Aluminized steel combustion chamber
- Dual inlet blower wheel
- Five chrome-plated racks, eleven rack positions with a minimum of 1-5/8" (41mm) spacing
- Interior lights

OPERATION

- Gas system combines direct and indirect heat
- Electronic spark ignition control system
- Removable dual tube burners
- Pressure regulator
- Manual gas service cut-off switch located on the front of the control panel
- Air mixers with adjustable air shutters
- Solid state thermostat with temperature control range of 200°F (93°C) to 500°F (260°C)
- Two speed fan motor (60 Hz only, not available in 50 Hz)
- 1/3 horsepower blower motor with automatic thermal overload protection
- Control area cooling fan
- Two 50 watt commercial bake oven lamps

STANDARD FEATURES

- Solid state manual control with separate dials to control thermostat and timer
- 25" (635mm) adjustable stainless steel legs (for single units)
- 6" (152mm) adjustable stainless steel legs (for double sections)

OPTIONS AND ACCESSORIES

(AT ADDITIONAL CHARGE)

■ Legs/casters/stands

- 6" (152mm) seismic legs
- 6" (152mm) casters
- 4-1/4" (108mm) low profile casters (double stack only)
- 25" (635mm) stainless steel open stand with rack guides

■ Venting

- Draft diverter
- Draft hood
- Extra oven racks
- Stainless steel solid back panel
- Gas manifold (for double sections)
- Flue connector

(AT NO ADDITIONAL CHARGE)

- Solid stainless steel doors



For cooking

WWW.JADERANGE.COM

JADE RANGE, LLC., A MIDDLEBY COMPANY • 2650 Orbiter Street • Brea, CA 92821 • PHONE: 800-884-5233 FAX: 714-961-2550
 Note: In line with their policy to continually improve products, Jade reserves the right to change materials and specifications without notice. PRINTED IN USA





FULL SIZE CONVECTION OVENS

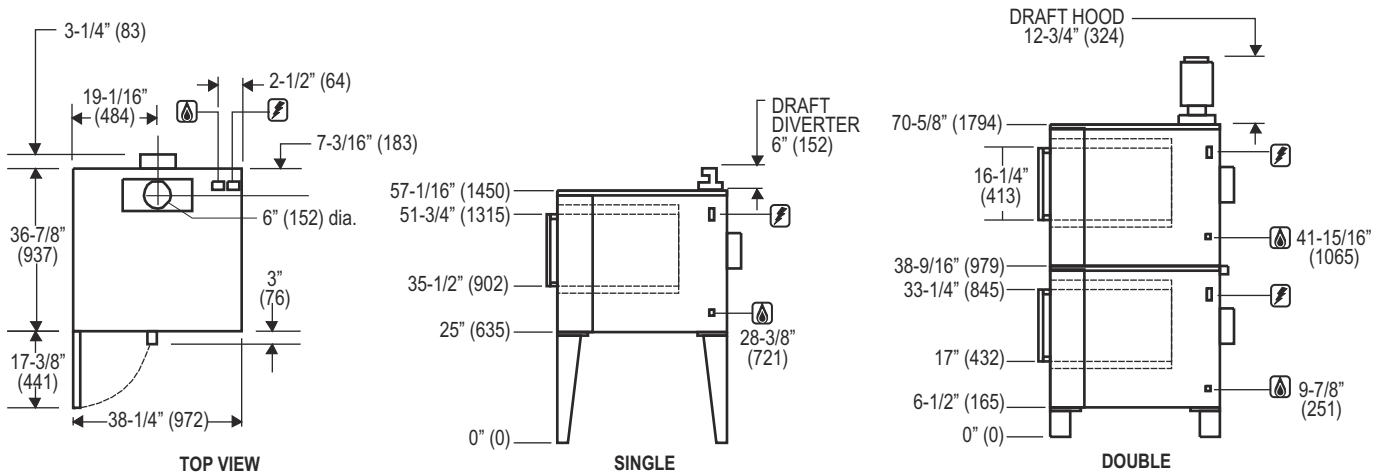

Dimensions are in inches (mm)

*Height on legs, if oven is on casters add to all height dimensions:
Single 4-1/4" (114mm) - Double 2-1/2" (57mm)

Interior Oven Cavity (per section)

Width = 29" (737 mm); Depth = 20" (508 mm); Height = 24-1/4" (616 mm)

MODEL	BTUS	WIDTH	DEPTH	HEIGHT	APPX. SHP. WT.
JCO-40B	55,000	38-1/4"	36-7/8"	57-1/16"	590 LBS.
JCO-240B	110,000	38-1/4"	36-7/8"	70-5/8"	1095 LBS.

DESCRIPTION:

Provide Jade full-size convection oven, Jade Range LLC model JCO-_____ (single/double) compartment. Each compartment shall have stainless steel liner and shall accept five 18" x 26" standard full-size bake pans. Stainless steel front, top and sides. One door shall be solid stainless steel and one shall have a dual pane thermal glass window. Unit shall have single porcelain handle with simultaneous operation. Unit shall be gas heated with electronic spark ignition and shall cook by means of combining direct and indirect heat with a gas shutoff switch on the front of the control panel. Air in baking chamber distributed by dual inlet blower wheel powered by a two-speed, 1/3 HP motor with thermal overload protection. Each chamber shall be fitted with two commercial lamps and five chrome-plated removable racks. Control panel shall be recessed with Cook/Cool Down mode selector, solid state (manual/digital) infinite thermostat (200- 500°F), and 60- minute timer. Provide options and accessories as indicated.

SPECIFY TYPE OF GAS WHEN ORDERING.

SPECIFY ALTITUDE WHEN ABOVE 2,000 ft.

UTILITY INFORMATION - GAS:

- Ranges are supplied with 3/4" capped rear gas connection. Ranges are supplied with 3/4" gas pressure regulator.
- Required operating pressure:
Natural Gas 5" W.C. minimum
Propane Gas 10" W.C. minimum
14" W.C. maximum

Note: This unit must be connected with the gas appliance regulator supplied.

UTILITY INFORMATION - ELECTRICAL:

- Standard: 115v/60/1 (for other electrical requirements consult factory)



WWW.JADERANGE.COM

JADE RANGE, LLC., A MIDDLEBY COMPANY • 2650 Orbiter Street • Brea, CA 92821 • PHONE: 800-884-5233 FAX: 714-961-2550
Note: In line with their policy to continually improve products, Jade reserves the right to change materials and specifications without notice. PRINTED IN USA