

THERMOSTATIC "GROOVED" GRIDDLES



JGGT-2436



JGGT-2436 (shown with ST-36)

DESCRIPTION

Thermostatically controlled grooved griddle to be Model #JGGT-_____ manufactured by Jade Range. To have 24" deep highly polished steel grooved and pitched plate 1" thick and one thermostatically controlled 24,000 BTU/hr. burner, each 12" of griddle. Provide stainless steel pitched gutter with full 2" x 3" drain. Furnish 3" high stainless steel rear and side splashes. To be of 14 gauge stainless steel all welded construction with stainless steel front, plate shelf, pilot tips, gas tubing throughout and legs with adjustable feet. Unit will have a 3/4" gas regulator.

OPEN BURNERS

Two 27,500 BTU cast iron open burners per 12" section with one 12" x 24" Lift-off cast iron top grate, each to have one stainless steel pilot per burner.

SPECIFY TYPE OF GAS WHEN ORDERING.

SPECIFY ALTITUDE WHEN ABOVE 2,000 FT.

MODEL NO.

DESCRIPTION

<input type="checkbox"/> JGGT-2424	24" WIDE THERMO-GROOVED GRIDDLE
<input type="checkbox"/> JGGT-2436	36" WIDE THERMO-GROOVED GRIDDLE
<input type="checkbox"/> JGGT-2448	48" WIDE THERMO-GROOVED GRIDDLE
<input type="checkbox"/> JGGT-2460	60" WIDE THERMO-GROOVED GRIDDLE
<input type="checkbox"/> JGGT-2472	72" WIDE THERMO-GROOVED GRIDDLE
<input type="checkbox"/> JGGT-2484	84" WIDE THERMO-GROOVED GRIDDLE
<input type="checkbox"/> FLOOR MODEL	ADD "F" TO END OF MODEL NUMBER
<input type="checkbox"/> 2 OPEN BURNERS	ADD "-2" TO MODEL NUMBER (INCREASES WIDTH BY 12")
<input type="checkbox"/> 4 OPEN BURNERS	ADD "-4" TO MODEL NUMBER (INCREASES WIDTH BY 24")
<input type="checkbox"/> 6 OPEN BURNERS	ADD "-6" TO MODEL NUMBER (INCREASES WIDTH BY 36")
<input type="checkbox"/> BURNERS ON LEFT	ADD "L" BEHIND NUMBER OF BURNERS ADDED

Example: JGGT-2436-2L-F: Floor model thermostatic-grooved griddle 36" wide with two open burners on left. (Burners are standard on right).

STANDARD FEATURES

- Stainless steel sides, front, and plate shelf
- Full 24" deep highly polished grooved and pitched steel plate 1" thick
- One thermostatically controlled 24,000 BTU/hr. burner every 12" of griddle.
- Stainless steel pitched gutter with 2" x 3" drain
- 3" high stainless steel rear and side splashes
- 14 gauge stainless steel all welded construction
- Stainless steel legs welded into the frame
- High capacity 14 gauge welded drip tray
- Stainless steel gas tubing throughout
- Stainless steel pilot tips resist corrosion
- 3/4" gas regulator, included

OPTIONS & ACCESSORIES

- Stainless steel 8" extended plate shelf
- 8" deep cutting board, Poly
- 6" casters, front two locking (floor models only)
- 36" flex hose with quick disconnect & restraining device
- 48" flex hose with quick disconnect & restraining device



THERMOSTATIC "GROOVED" GRIDDLES

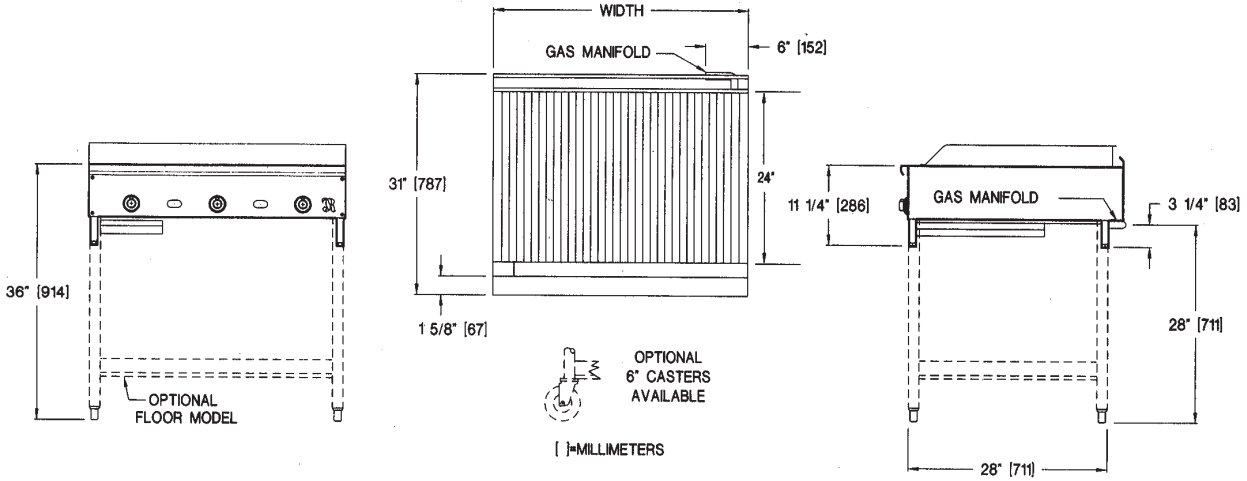

MODEL	BTUS	WIDTH	DEPTH	HEIGHT	APPX. SHP. WT.	APPX. CUBE COUNTER/FLOOR
JGGT-2424	48,000	24"	31"	SEE DRAWING	260 LBS.	15/24
JGGT-2436	72,000	36"	31"	SEE DRAWING	350 LBS.	21/38
JGGT-2448	96,000	48"	31"	SEE DRAWING	450 LBS.	27/49
JGGT-2460	120,000	60"	31"	SEE DRAWING	520 LBS.	33/62
JGGT-2472	144,000	72"	31"	SEE DRAWING	630 LBS.	39/72
JGGT-2484	168,000	84"	31"	SEE DRAWING	750 LBS.	45/83
OPEN BURNER SECTIONS						
-2	55,000*	12"*	31"	SEE DRAWING	80 LBS.*	
-4	110,000*	24"*	31"	SEE DRAWING	140 LBS.*	
-6	165,000*	36"*	31"	SEE DRAWING	210 LBS.*	

* Add to above units respective quantities.

NOTE: SPECIFY TYPE OF GAS WHEN ORDERING.

UTILITY INFORMATION:

- 3/4" Connection
- Required operating pressure:
 Natural Gas 5" W.C. minimum
 Propane Gas 10" W.C. minimum
 14" W.C. maximum

Note: This unit must be connected with the gas appliance regulator supplied.



WWW.JADERANGE.COM

JADE RANGE, LLC., A MIDDLEBY COMPANY • 2650 Orbiter Street • Brea, CA 92821 • PHONE: 800-884-5233 FAX: 714-961-2550
 Note: In line with their policy to continually improve products, Jade reserves the right to change materials and specifications without notice. PRINTED IN USA