



# MESQUITE BROILER CIRCULAR

TITAN MESQUITE BROILER CIRCULAR



JMB-36

MODEL NO.	DESCRIPTION
<input type="checkbox"/> JMB-36	36" MESQUITE BROILER
<input type="checkbox"/> JMB-42	42" MESQUITE BROILER

### STANDARD FEATURES

- One-piece fuel container (body)—deep drawn from heavy plate steel
- 1" thick hi-temp refractive ceramic insulating liner bonded to interior liner
- Completely mobile—no gas "hook-up" (recommended fuel is mesquite chips)
- Cooking grid is manufactured from steel rod, and welded for superior strength and long life
- Grid can be independently raised or lowered by the unique balance mechanism to control product temperature requirements
- Body has front cleaning hatch for easy removal of ashes
- 12 gauge all welded firebox construction
- 3" casters, front two locking

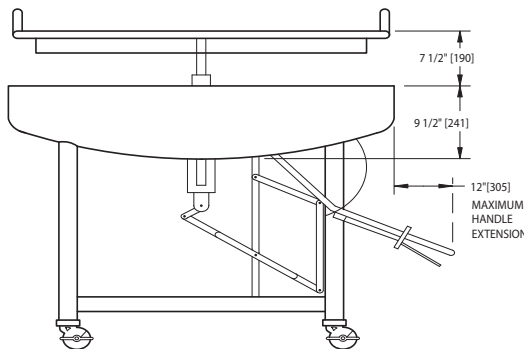
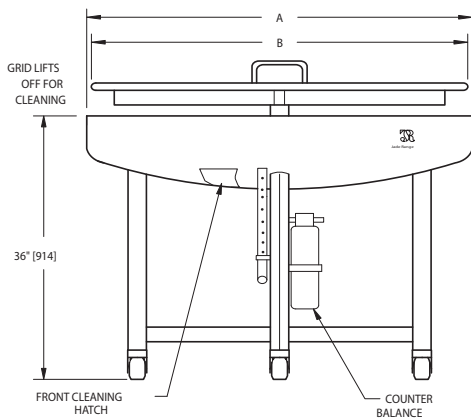
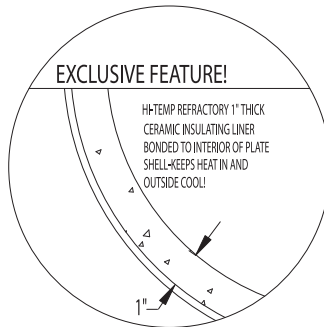

MODEL	O.A. (A)	GRID (B)
JMB-36	36"	35"
JMB-42	42"	41"



WWW.JADERANGE.COM

JADE RANGE, LLC., A MIDDLEBY COMPANY • 2650 Orbiter Street • Brea, CA 92821 • PHONE: 800-884-5233 FAX: 714-961-2550  
 Note: In line with their policy to continually improve products, Jade reserves the right to change materials and specifications without notice. PRINTED IN USA

