

REVISIONS				
REV.	DESCRIPTION	ECN	INITIALS	DATE
A	DWG RELEASED WITH RESTRUCTURED BOM	6203A	JLAM	8/16/2017
B	JCM-18 BURNER UPDATE FROM 1213500200 TO 3000013515	8693	MF	6/3/2022

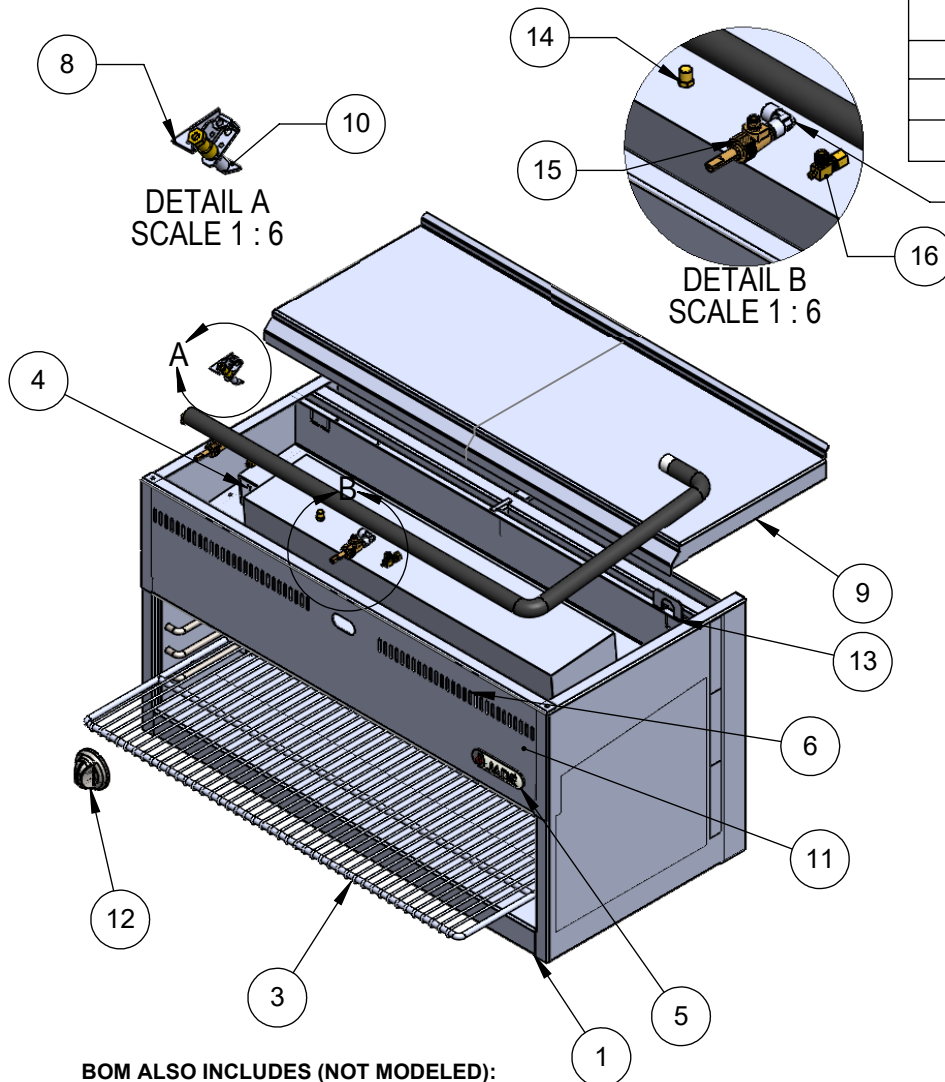

ITEM NO.	PART NUMBER	DESCRIPTION	EXPLODED VIEW /QTY.
1	2500129127	BODY WA, JCM-36	1
2	2500129139	MANIFOLD ASSY, JCM-36	1
3	1411200000	RACK, JCM-36, 13.25 X 33.50	1
4	1212300000	BURNER, IR, LARGE B35T FOR JCM	1
5	3000012160	NAMEPLATE, JADE LOGO RED/CHRM	1
6	9515000000	BRACKET, MANIFOLD HOLDER, JCM	2
7	3430400000	NUT, 1/4-20 WELD ZN	2
8	2100012479	BRACKET, PILOT, JCM	1
9	5912510000	TOP COVER, JCM-36	1
10	3000011694	PILOT, ALPHA BRASS B11H2 (FOR JCM)	1
11	2100001507	FRONT PANEL, JCM-36	1
12	3000012131	TITAN ARC KNOB 2.75	1
13	2100012534	ANCHOR PLATE, 3/4OD PIPE, JCM	1
14	1813000000	PLUG, 1/8 HX HD BLK	1
15	4418500000	VALVE BRNR 2" STEM	1
16	4412800000	VALVE, SINGLE PILOT	1
17	1830100000	ELBOW, 3/8 CC 3/8-27FT 90 DEG	1

BOM ALSO INCLUDES (NOT MODELED):

- 5615100000, FLEXIBLE TUBING 3/8 X 19", QTY 1
- 3000013479, FLEXIBLE TUBING 1/4 X 16", QTY 1
- 1830700000, 1/4 COMPRESSION NUT, QTY 2
- 1832200000, 1/4 FERRULE, QTY 2
- 1833000000, 3/8 COMPRESSION NUT, QTY 2
- 1816900000, 3/8 FERRULE, QTY 2

NOTES UNLESS OTHERWISE SPECIFIED:

1. DIMENSIONS ARE IN INCHES. DIMENSIONS IN (OVAL) ARE CRITICAL TO QUALITY. DIMENSIONS IN (PARENTHESIS) ARE FOR REFERENCE ONLY.
2. MATERIAL: PVC UP.<<<GRAIN>>>
3. REMOVE ALL BURRS AND SHARP EDGES.

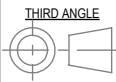
<p>THE INFORMATION CONTAINED IN THIS DRAWING IS THE PROPERTY OF</p>  <p>JADE RANGE, LLC 2650 ORBITER ST BREA, CA 92821</p>	<p>TOLERANCES: .XXX ± .03 .XX ± .06 ANGLES ± 1°</p>	<p>THIRD ANGLE</p> 	<p>DESC. JCM-36</p>
	<p>MATERIAL SIZE in²</p>	<p>DWG No. 2900012090</p>	<p>DRAWN: J.LAM</p>
			<p>REV. B</p>

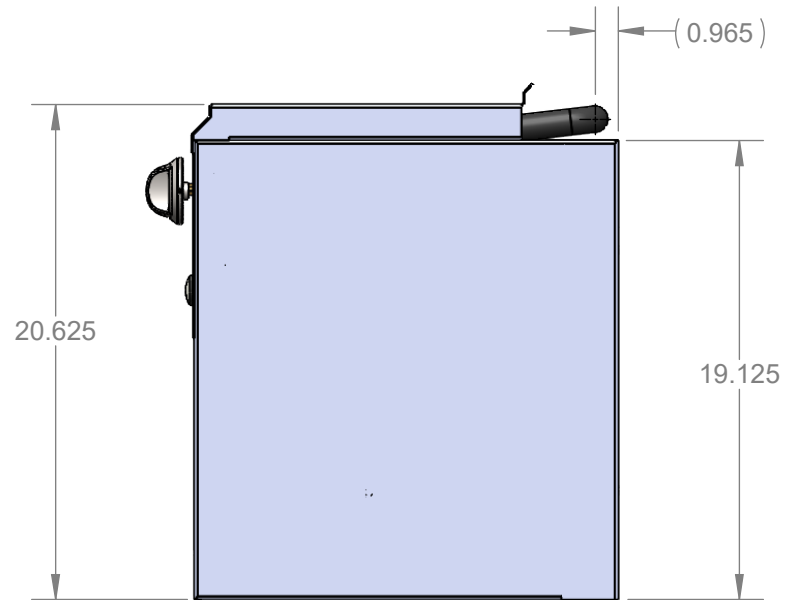
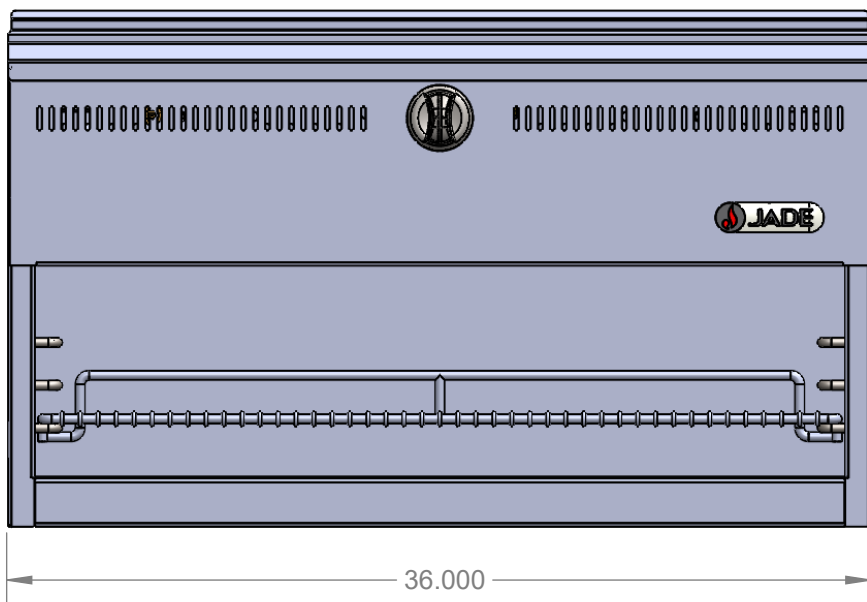
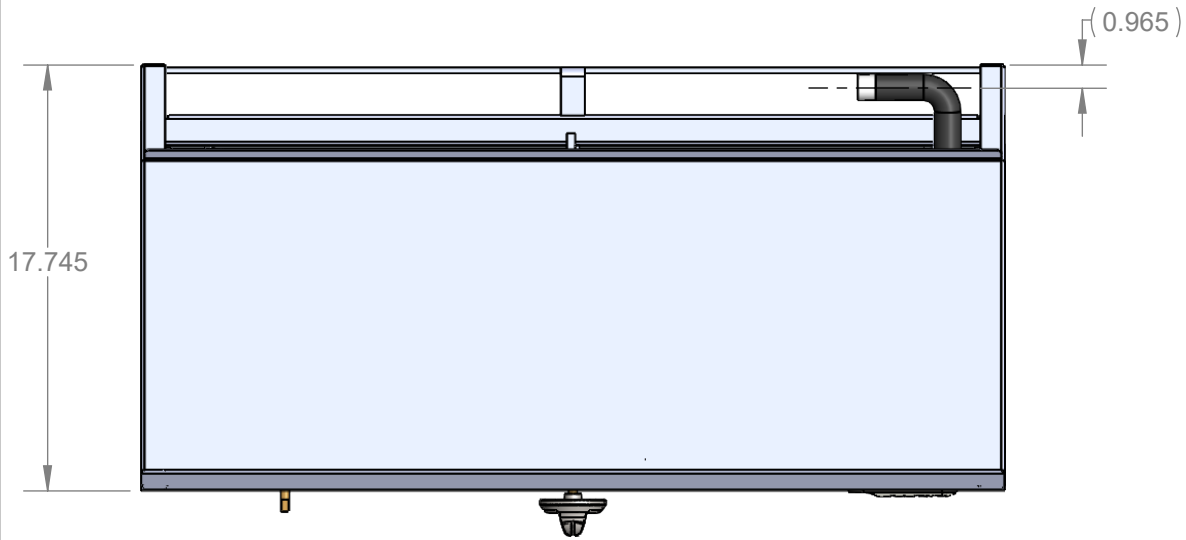

THE INFORMATION CONTAINED IN
THIS DRAWING IS THE PROPERTY OF



JADE

JADE RANGE, LLC
2650 ORBITER ST BREA, CA 92821

DESC. JCM-36		
DWG No. 2900012090		
DRAWN: J.LAM	DATE: 8/8/2017	REV. B

BURNER, ORIFICE, RACK, AND RR MOUNT PNL CHART FOR JCM'S

MODEL NUMBER	PART NUMBER	BRNR #1	QTY	ORIFICE NAT	ORIFICE L/P	BRNR #2	QTY	ORIFICE NAT	ORIFICE L/P	RACK, QTY 1	RR MOUNT PNL
JCM-18-SSI	2900012087	3000013515	1	48	55	N/A	N/A	N/A	N/A	3000011099	2100013606
JCM-24-SSI	2900012088	1212500000	1	46	55	N/A	N/A	N/A	N/A	1411100000	2100013605
JCM-30-SSI	2900012089	1212500000	1	46	55	N/A	N/A	N/A	N/A	3000011483	2100013070
JCM-36-SSI	2900012090	1212300000	1	40	52	N/A	N/A	N/A	N/A	1411200000	2100013607
JCM-42-SSI	2900013283	1212300000	1	40	52	N/A	N/A	N/A	N/A	3000012480	2100020057
JCM-48-SSI	2900012091	1212500000	2	46	55	N/A	N/A	N/A	N/A	1411300000	2100013608
JCM-54-SSI	2900012092	1212500000	2	46	55	N/A	N/A	N/A	N/A	1411310000	2100013609
JCM-60-SSI	2900012093	1212300000	1	40	52	1212500000	1	46	55	1411400000	2100013610
JCM-72-SSI	2900012094	1212300000	2	40	52	N/A	N/A	N/A	N/A	1411500000	2100013611
JCM-84-SSI	2900012095	1212300000	1	40	52	1212500000	2	46	55	1411600000	2100013612
JCM-96-SSI	2900012096	1212500000	4	46	55	N/A	N/A	N/A	N/A	1411700000	2100013613
JCM-108-SSI	2900012097	1212300000	3	40	52	N/A	N/A	N/A	N/A	1411800000	2100013614
JCM-120-SSI	2900012098	1212300000	2	40	52	1212500000	2	46	55	1411900000	2100013615

THE INFORMATION CONTAINED IN THIS DRAWING IS THE PROPERTY OF



JADE
 JADE RANGE, LLC
 2650 ORBITER ST BREA, CA 92821

DESC.
JCM-36

DWG No.
2900012090

DRAWN: J.LAM DATE: 8/8/2017 REV. B

REVISIONS				
REV.	DESCRIPTION	ECN	INITIALS	DATE
A	DWG RELEASED; MODELED BASED ON PHYSICAL INSPECTION	6203	JLAM	8/16/2017

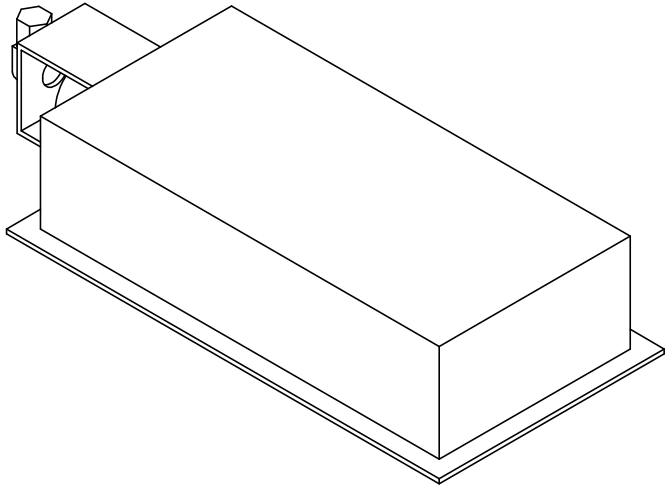
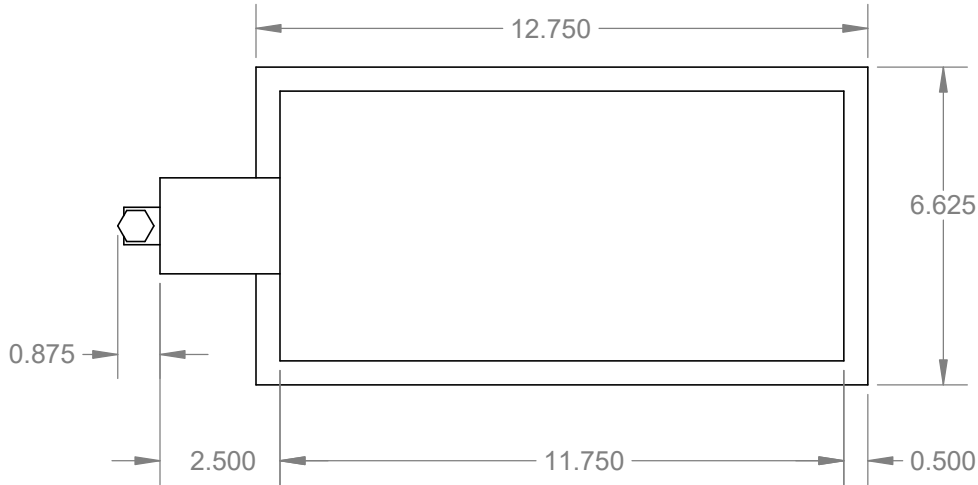

ORIFICE COMES WITH IR BURNER

NOTES UNLESS OTHERWISE SPECIFIED:

1. DIMENSIONS ARE IN INCHES. DIMENSIONS IN (OVAL) ARE CRITICAL TO QUALITY. DIMENSIONS IN (PARENTHESIS) ARE FOR REFERENCE ONLY.
2. MATERIAL:.
3. PVC UP.<<<GRAIN>>>
4. REMOVE ALL BURRS AND SHARP EDGES.

THIS JADE PART NUMBER REPLACES VIKING PART NUMBER 039062-000.

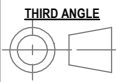
<p>THE INFORMATION CONTAINED IN THIS DRAWING IS THE PROPERTY OF</p>  <p>JADE</p> <p>JADE RANGE, LLC 2650 ORBITER ST BREÁ, CA 92821</p>	<p>TOLERANCES: .XXX ±.03 .XX ±.06 ANGLES ±1°</p>	<p>THIRD ANGLE</p> 	<p>DESC. BURNER, IR, B-15 FOR JCM-18</p>
	<p>MATERIAL SIZE</p> <p>in²</p>	<p>DWG No. 3000013515</p>	<p>DRAWN : _____</p>

REV. A

REVISIONS

REV.	DESCRIPTION	ECN	INITIALS	DATE
------	-------------	-----	----------	------

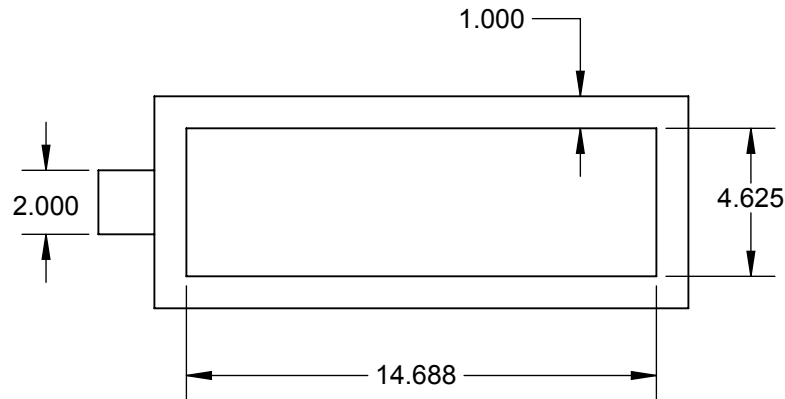
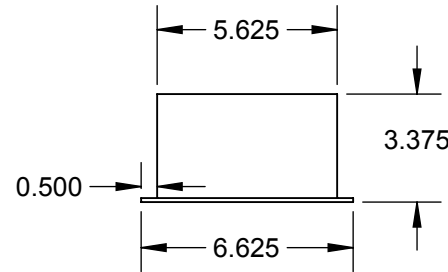
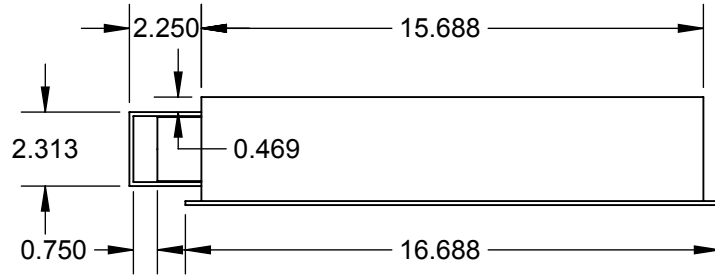
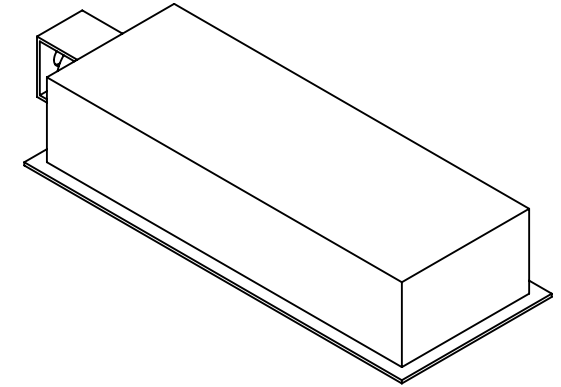

NOTES UNLESS OTHERWISE SPECIFIED:

1. DIMENSIONS ARE IN INCHES. DIMENSIONS IN (OVAL) ARE CRITICAL TO QUALITY. DIMENSIONS IN (PARENTHESIS) ARE FOR REFERENCE ONLY.
2. MATERIAL:.
3. PVC UP.<<<GRAIN>>>
4. REMOVE ALL BURRS AND SHARP EDGES.

THE INFORMATION CONTAINED IN THIS DRAWING IS THE PROPERTY OF



JADE RANGE, LLC
2650 ORBITER ST BREA, CA 92821

TOLERANCES:
.XXX ± .03 .XX ± .06
ANGLES ± 1°

THIRD ANGLE

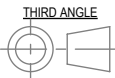

MATERIAL SIZE
in²

DESC.
BURNER, IR, SMALL B20T FOR JCM

DWG No. **1212500000**

DRAWN: DATE: REV. **A**

REVISIONS

REV.	DESCRIPTION	ECN	INITIALS	DATE
------	-------------	-----	----------	------

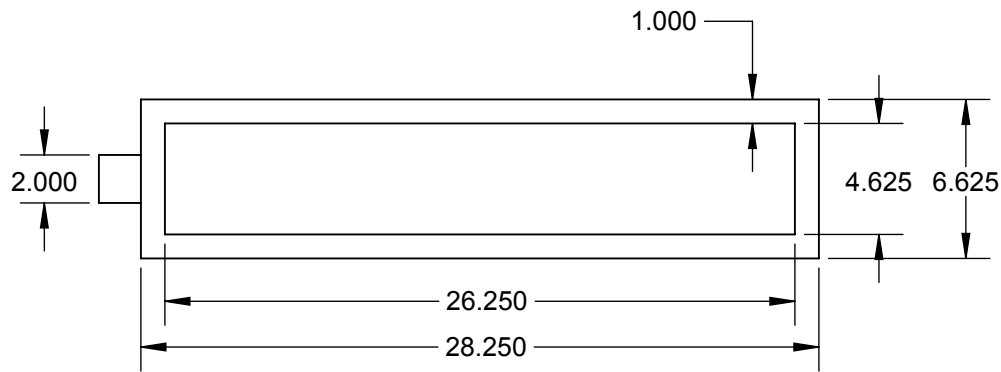
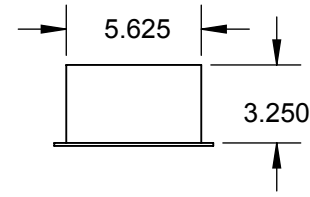
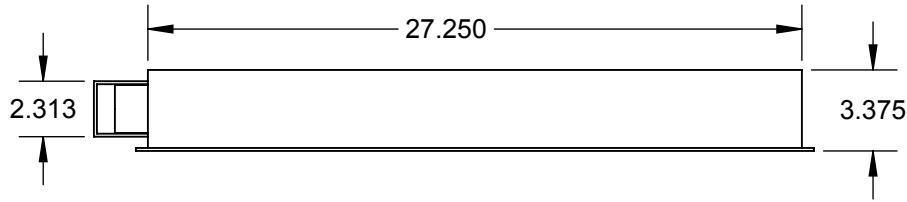
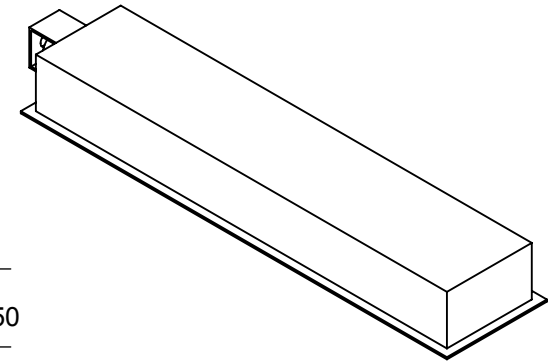

NOTES UNLESS OTHERWISE SPECIFIED:

1. DIMENSIONS ARE IN INCHES. DIMENSIONS IN (OVAL) ARE CRITICAL TO QUALITY. DIMENSIONS IN (PARENTHESES) ARE FOR REFERENCE ONLY.
2. MATERIAL:.
3. PVC UP.<<<GRAIN>>>
4. REMOVE ALL BURRS AND SHARP EDGES.

THE INFORMATION CONTAINED IN THIS DRAWING IS THE PROPERTY OF



JADE RANGE, LLC
2650 ORBITER ST BREÁ, CA 92821

TOLERANCES:
.XXX ± .03 .XX ± .06
ANGLES ± 1°

THIRD ANGLE

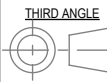

MATERIAL SIZE
in²

DESC.
BURNER, IR, LARGE B35T FOR JCM

DWG No. **1212300000**

DRAWN: DATE: REV. **A**