

REVISIONS

REV.	DESCRIPTION	ECN	INITIALS	DATE
A	RE-DID BOM		JFP	10/28/2021

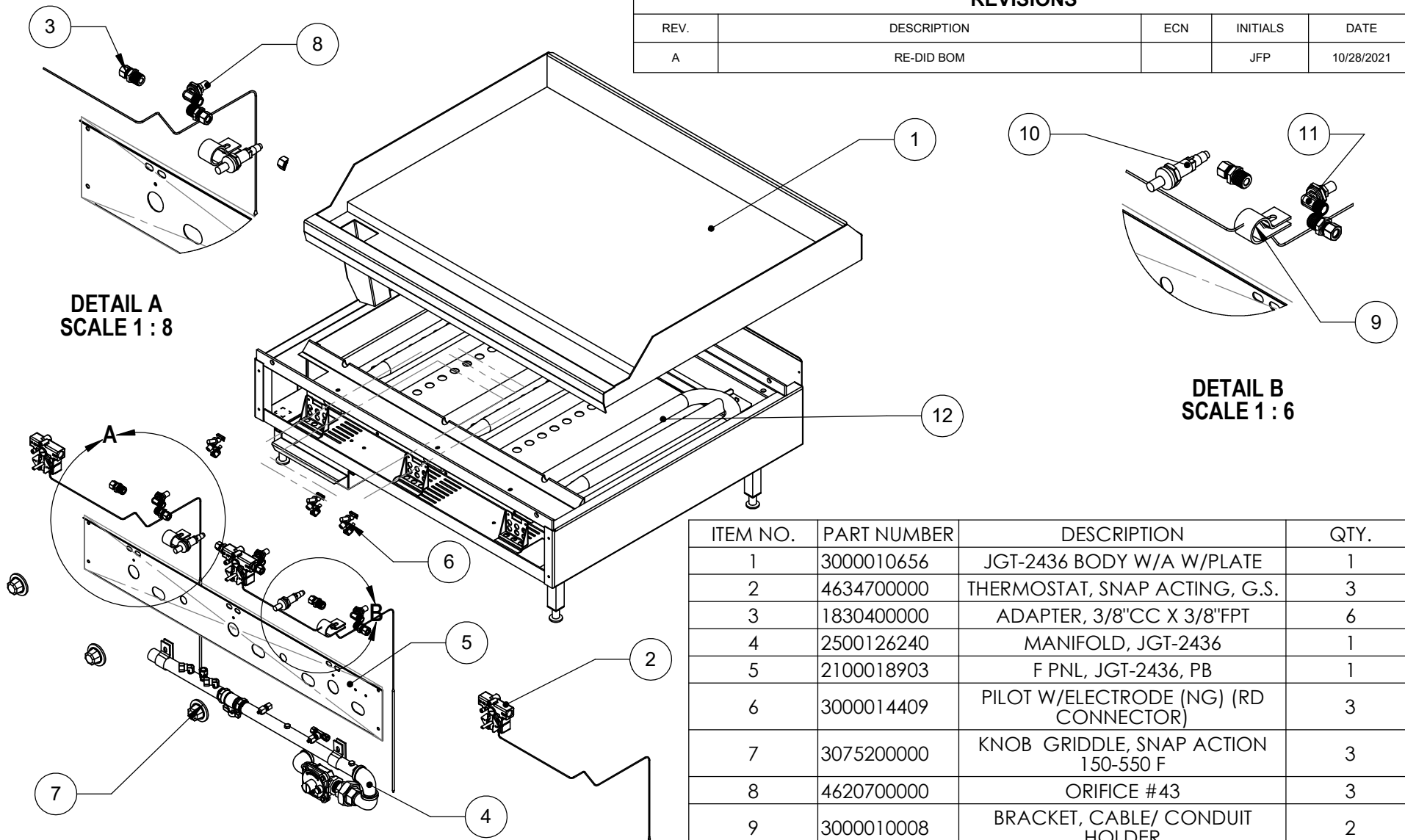

**DETAIL A
SCALE 1 : 8**

**DETAIL B
SCALE 1 : 6**

ITEM NO.	PART NUMBER	DESCRIPTION	QTY.
1	3000010656	JGT-2436 BODY W/A W/PLATE	1
2	4634700000	THERMOSTAT, SNAP ACTING, G.S.	3
3	1830400000	ADAPTER, 3/8"CC X 3/8" FPT	6
4	2500126240	MANIFOLD, JGT-2436	1
5	2100018903	F PNL, JGT-2436, PB	1
6	3000014409	PILOT W/ELECTRODE (NG) (RD CONNECTOR)	3
7	3075200000	KNOB GRIDDLE, SNAP ACTION 150-550 F	3
8	4620700000	ORIFICE #43	3
9	3000010008	BRACKET, CABLE/ CONDUIT HOLDER	2
10	3000013318	PIEZO IGNITER, PUSH, 2 OUTPUT	2
11	1815700000	ORIFICE, ELBOW	3
12	1216100000	BURNER,U,23 3/4"STD,JGT,JSR	3

NOTES UNLESS OTHERWISE SPECIFIED:

- DIMENSIONS ARE IN INCHES. DIMENSIONS IN OVAL ARE CRITICAL TO QUALITY. DIMENSIONS IN (PARENTHESIS) ARE FOR REFERENCE ONLY.
- MATERIAL:
- PVC UP.<<<GRAIN>>>
- REMOVE ALL BURRS AND SHARP EDGES.

THE INFORMATION CONTAINED IN THIS DRAWING IS THE PROPERTY OF



JADE RANGE, LLC
2650 ORBITER ST BREA, CA 92821

TOLERANCES:
.XXX ±.03 .XX ±.06
ANGLES ±1°

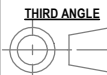

MATERIAL SIZE

in²

DESC.

JGT-2436 W/PB

DWG No.

JGT2436001

DRAWN
:F.PARRA

DATE:
11/8/2019

REV.
A